

## PART A – Engine, Engine Management and Turbocharger

### 1.1 Engine Components (Cylinder Head, cont'd.)

- The oil feed bores are located on the side of the support bearings.

The camshaft for the inlet valves has bearing journals with oil grooves to ensure complete lubrication of the bearing surface.

The camshaft for the exhaust valves does not need this oil groove because of the position of the oil feed bore.

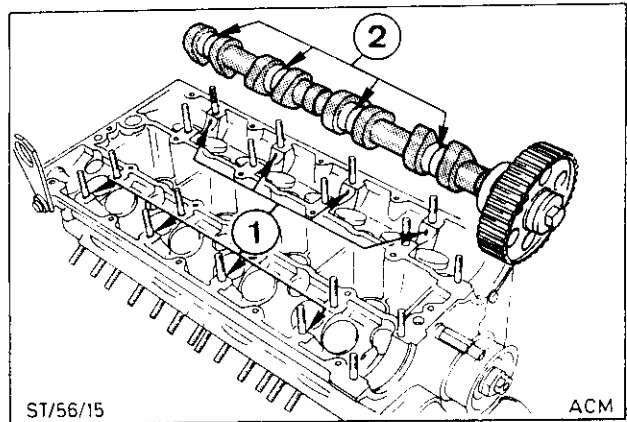

#### Lubrication of the camshaft

- 1 = Oil supply bore
- 2 = Lubrication groove

- The hydraulic valve tappets (bucket type) are supplied as an assembly. They should not be disassembled and must always be fitted into their original location.

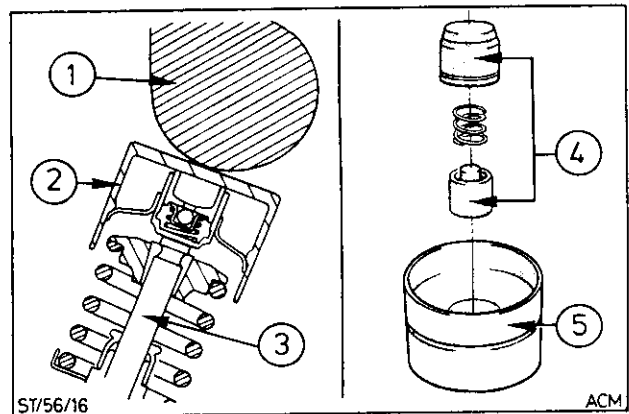

#### Hydraulic valve tappets

- 1 = Camshaft
- 2 = Hydraulic valve tappets
- 3 = Valve stem
- 4 = Piston, cylinder and spring of the hydraulic valve tappet
- 5 = Tappet housing with oil chamber

## PART A – Engine, Engine Management and Turbocharger

### 1.1 Engine Components (Cylinder Head, cont'd.)

- The oil gallery of the cylinder head is fitted with a non-return valve which eliminates oil drain back after the engine is switched off

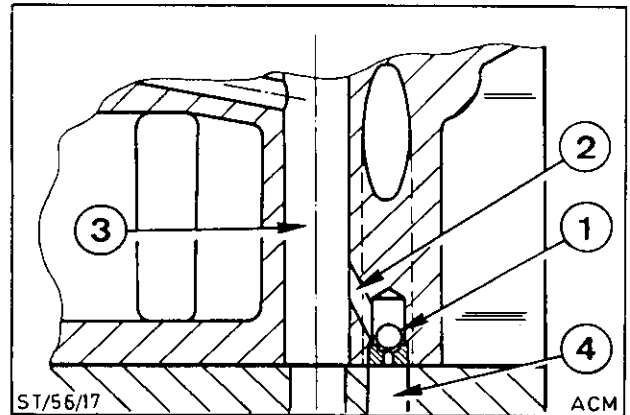

#### Anti-drain back valve in cylinder head

- 1 = Ball in closed position (engine switched off)
- 2 = Cross drilling
- 3 = Cylinder head bolt drilling (oil gallery)
- 4 = Main oil gallery

When starting the engine the anti-drain back valve opens for immediate lubrication of the camshaft journals and hydraulic tappets.

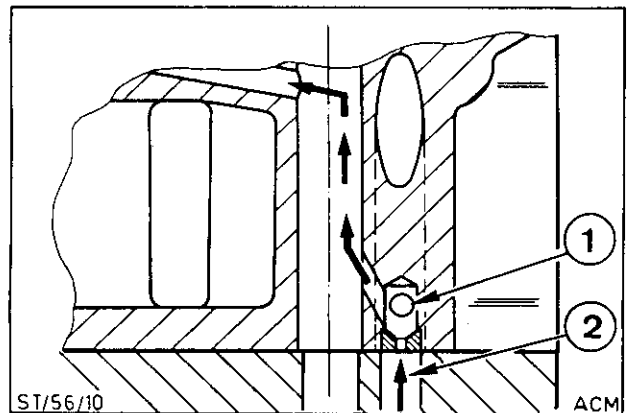

#### Anti-drain back valve in cylinder head

- 1 = Ball in open position (with engine in operation)
- 2 = Direction of oil flow

- The cylinder head gasket differs from the standard OHC gasket in that it has revised openings to match the Cosworth cylinder head.

## PART A – Engine, Engine Management and Turbocharger

### 1.1 Engine Components

#### Components fitted to the Cylinder Head

##### Inlet side:

- Inlet manifold (1)
- Air chamber (2) with bolted on fuel rail (3), pressure regulator (4) and push fit fuel injectors (5).
- Throttle housing (6) and elbow (7).

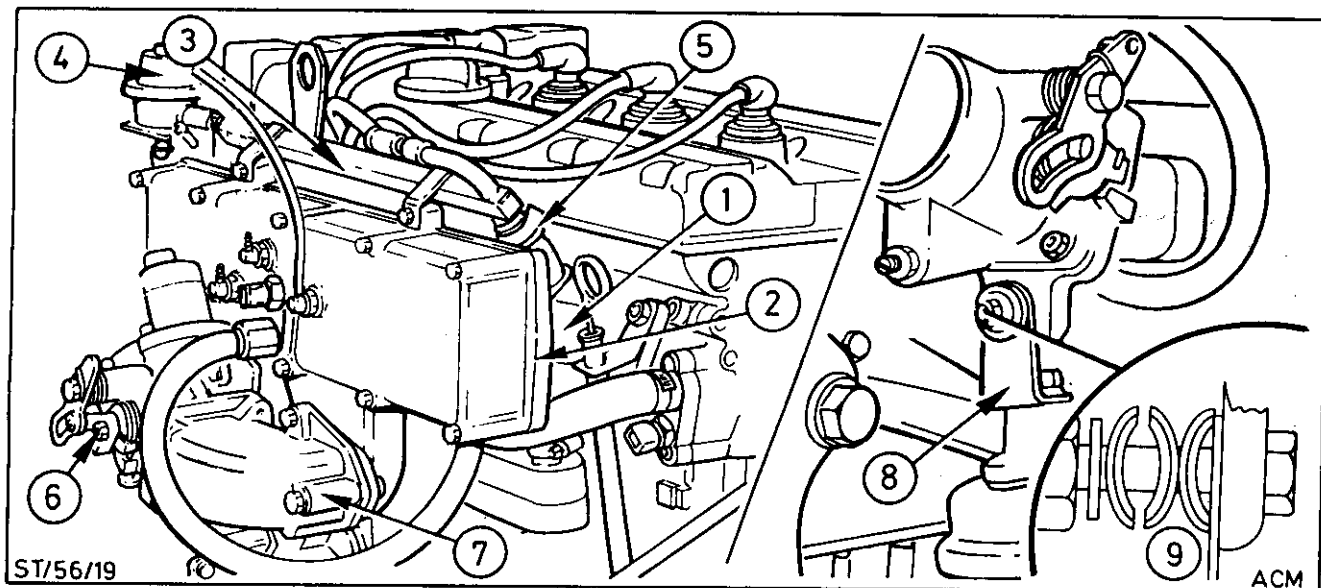

- The elbow is supported by a bracket (8) from the engine mounting. The elbow is fastened to the bracket by three pairs of special dished washers (9). This flexible mounting eliminates vibrations from the engine, which could affect the throttle position sensor. When disassembling, the position of the dished washers should be noted to ensure correct reassembling.

##### Outlet side:

- Two piece exhaust manifold (1) consisting of the primary manifold and the secondary manifold. Because of the high exhaust temperature, the manifold material consists of a heat-resistant cast iron (Ni-resist).
- The turbocharger is water-cooled and bolted to the exhaust manifold.

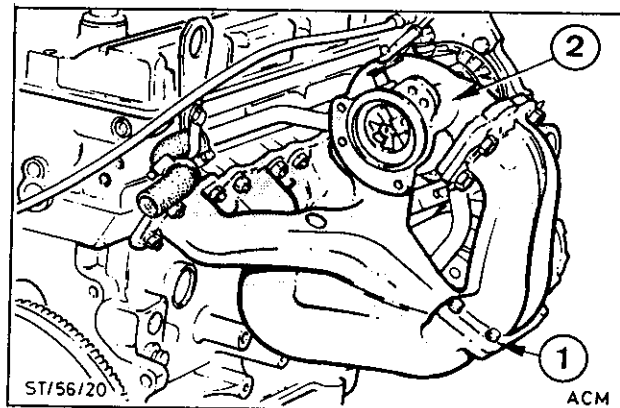

ENGINE MUST TICKOVER FOR 20 Sec Before Switching OFF.

# PART A – Engine, Engine Management and Turbocharger

## 1.1 Engine Components

### Front Belt Drive

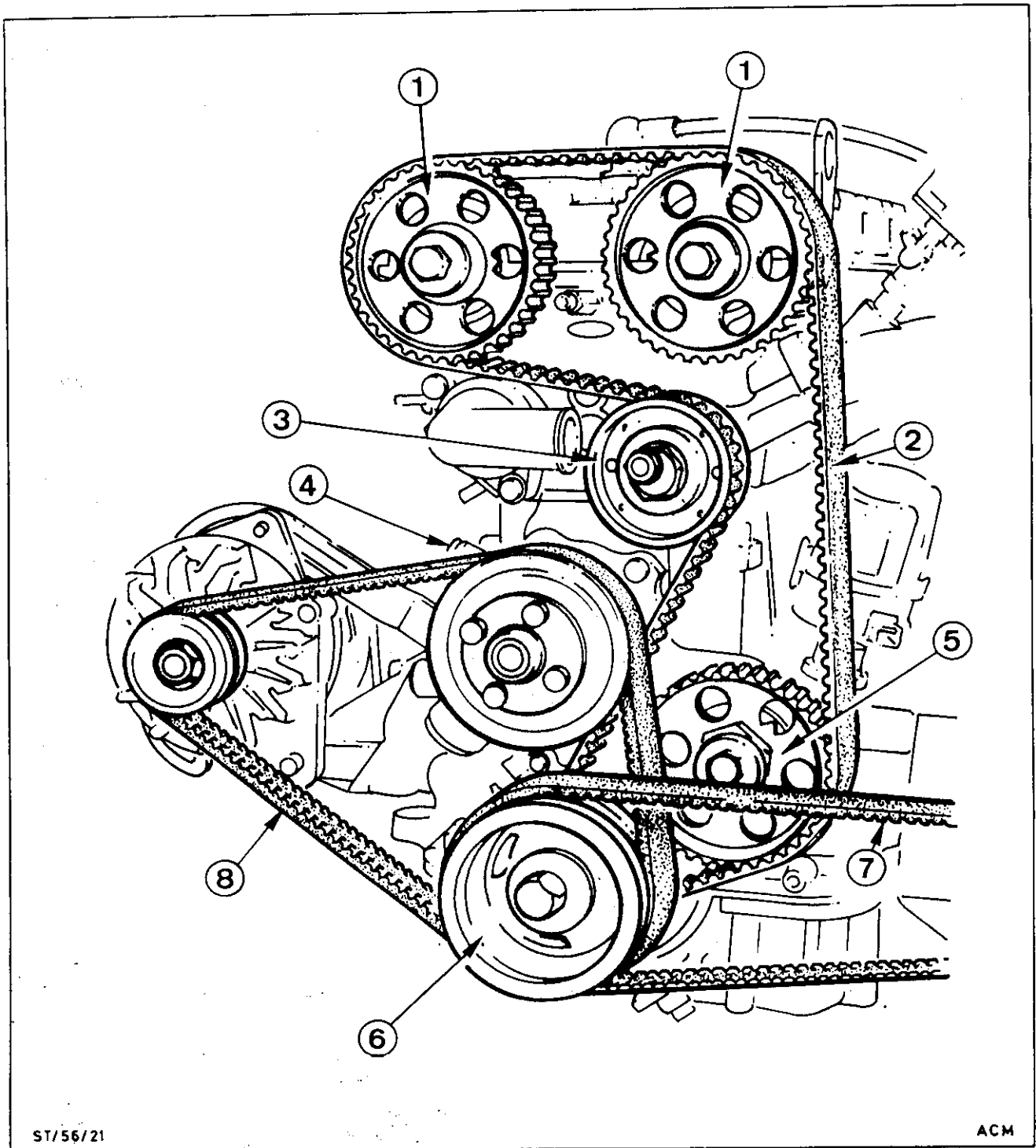

- 1 = Camshaft sprocket gear
- 2 = Timing belt
- 3 = Tensioner - timing belt
- 4 = Water pump

- 5 = Sprocket gear - auxiliary shaft
- 6 = Three belt pulley
- 7 = V-belt - power steering pump
- 8 = V-belt - alternator and water pump

## PART A – Engine, Engine Management and Turbocharger

### 1.1 Engine Components (Front Belt Drive, cont'd.)

- The overhead camshafts and the auxiliary shaft are driven by a toothed timing belt directly from the crankshaft sprocket gear. The timing belt must be replaced in service every 80.000 km (50.000 miles).
- The sprockets for the camshafts and the auxiliary shaft are located by keys.
- In contrast to the standard OHC-engine the Cosworth engine has a TDC marking on the sprocket gear for the auxiliary drive.
- The eccentric type belt tensioner allows a very precise setting of the timing belt tension.
- The fan belt pulley on the crankshaft drives three belts, a matched pair for the alternator and the water pump and a single belt for the power steering pump.
- Tensioning of the "V" belts for the alternator and the water pump is done on the bracket for the alternator. The procedure is similar to the one for the standard OHC-engine. Tension of the "V" belt for the power steering pump is achieved by tilting the power steering pump.

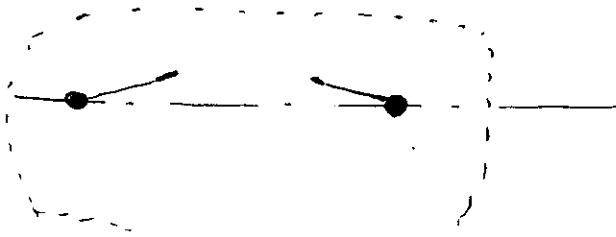

- There are 4 teeth on the "V" belt pulley nearest to the engine. These teeth are separated by exactly 90°. They initiate the pulses for the speed sensor (see "Engine Management").

The tooth next to the ignition timing mark identifies the TDC position of piston No. 1. This position is reached when the flank of the tooth aligns with the marking on the front cover (see illustration). The TDC position for the camshafts and the auxiliary shaft is set using the timing marks on the sprocket gears and the markings on the housing.

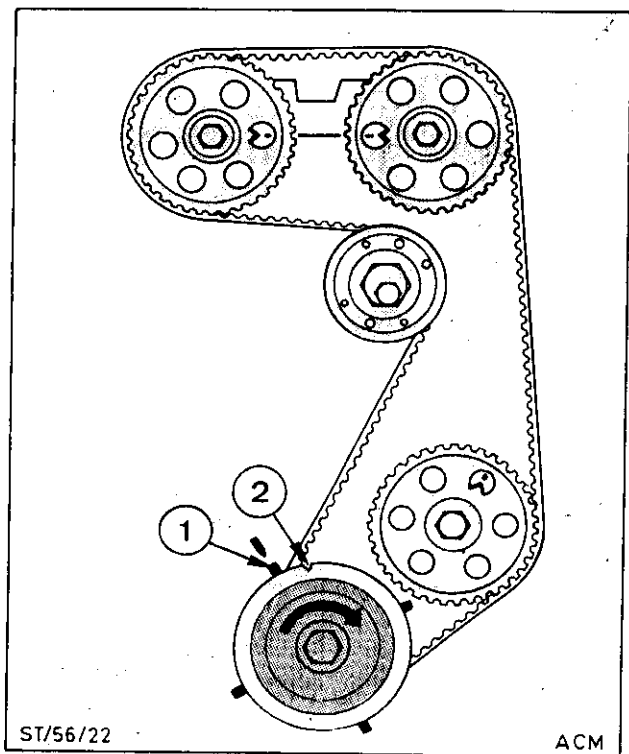

#### TDC Markings

- 1 = TDC position of cylinder "1"
- 2 = Ignition timing (16° BTDC)



## PART A – Engine, Engine Management and Turbocharger

### 1.1 Engine Components (Crank Case Assembly, cont'd.)

#### Cylinder Block

- The cylinder block is a specially selected standard production OHC block.
- **Cylinder blocks selected have either a standard bore grade 2 or 3.**
- The bore size of the individual cylinders (either class 2 or 3) is stamped into the cylinder block behind the distributor, starting with cylinder No. 1.

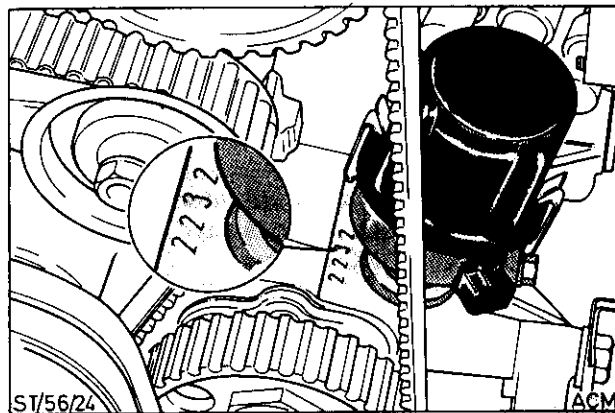

Identification of cylinder bores and piston grades

#### Crank Case Assembly

- The aluminium alloy pistons are either standard class 2 or 3.
- The pistons have a combustion bowl.
- The upper compression ring is chrome-plated. Both compression rings are marked "TOP".
- The piston pin is fully floating and secured by snap rings.

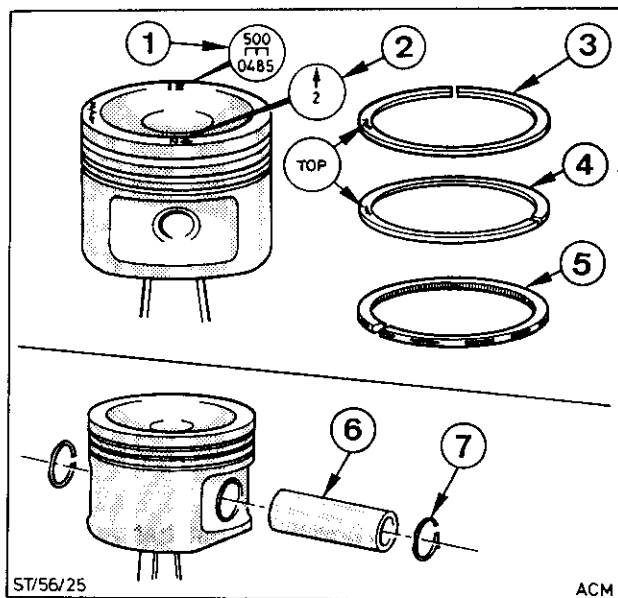

#### Piston, Piston Rings and Piston Pin

- 1 = Production date and Manufacturer sign
- 2 = Piston-standard class and arrow  
– engine front
- 3/4 = Compression rings with "TOP" mark
- 5 = Oil control rings
- 6 = Piston pin
- 7 = Snap ring

## PART A – Engine, Engine Management and Turbocharger

### 1.1 Engine Components (Crank Case Assembly, cont'd.)

- The connecting rods have been redesigned to suit high performance engine.
- The crankshaft is dimensionally similar with the standard OHC crankshaft. However, the crankshaft is forged steel and bearing journals are specially hardened.
- The crankshaft is supported in five main bearings similar to the standard OHC engine. The centre main bearing is fitted with thrust half washers to control crankshaft endfloat, as on standard OHC engine.
- The main and connecting rod bearings are similar to the standard OHC engine but with improved bearing surface material. The procedure to measure bearing clearance is also similar. **Note:** The main bearing shells in the block have an oil groove.
- The crankshaft sprocket gear and the front and rear oil seals are similar to the standard OHC engine, but reinforced.
- Most special tools for removal and installation are also carry over from the OHC engine. The installation tool for the rear oil seal has two additional fastening holes to suit the revised hole circle in the flywheel.
- The flywheel is new and it is fastened to the crankshaft by 9 instead of 6 bolts. The diameter of the flywheel is approx. 25 mm larger than on the OHC engine (without ring gear).

The flywheel and the crankshaft are balanced together during manufacture. The correct position of the flywheel to the crankshaft is ensured by unequal spacings between the fastening holes. The space between the fastening holes "A" is smaller than between the others.

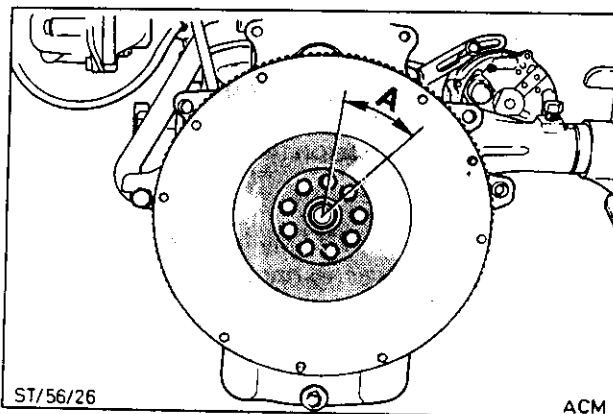

**Hole circle in the flywheel**

A = Smaller spacing

## PART A – Engine, Engine Management and Turbocharger

### 1.1 Engine Components

#### Oilpump and Lubrication Circuit

- The oilpump is similar in design and operation to the pump fitted to the OHC engine.
- The cover of the pump has been revised to connect an additional oil pipe.

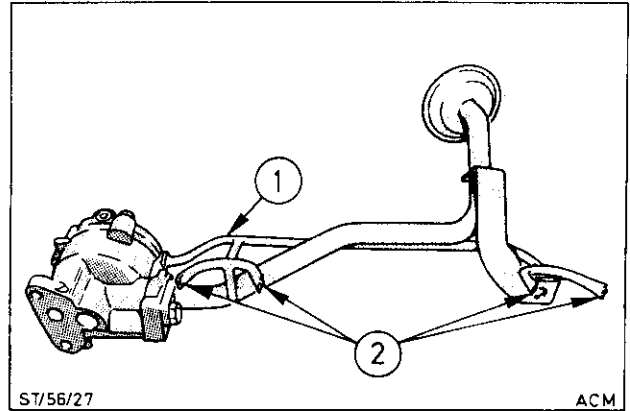

#### Oilpump

- 1 = Oilpipe
- 2 = Four spray pipes

- There are four spray pipes, one for each cylinder, which allow piston cooling by oil spray.

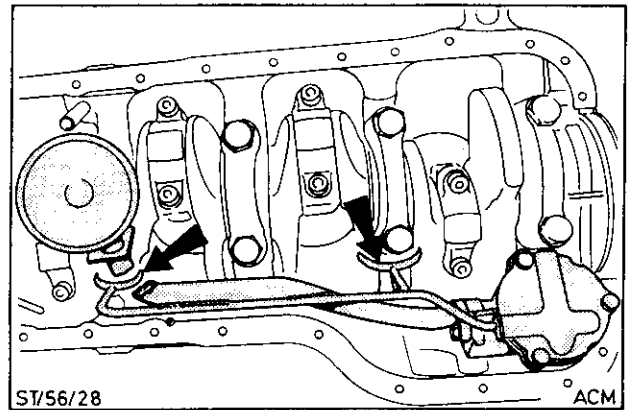

#### Position of the oilpump with spray pipe

- The oil pump draws oil from the sump and feeds it through an oil cooler and the full-flow filter into the main oil gallery which distributes the lubricant into the oil galleries in the same manner as on the standard OHC engine.

An oil gallery at the front end of the engine block feeds oil to the valve train and the hydraulic tappets.

A non return valve in the oil gallery of the cylinder head eliminates oil drain back after the engine is switched off.

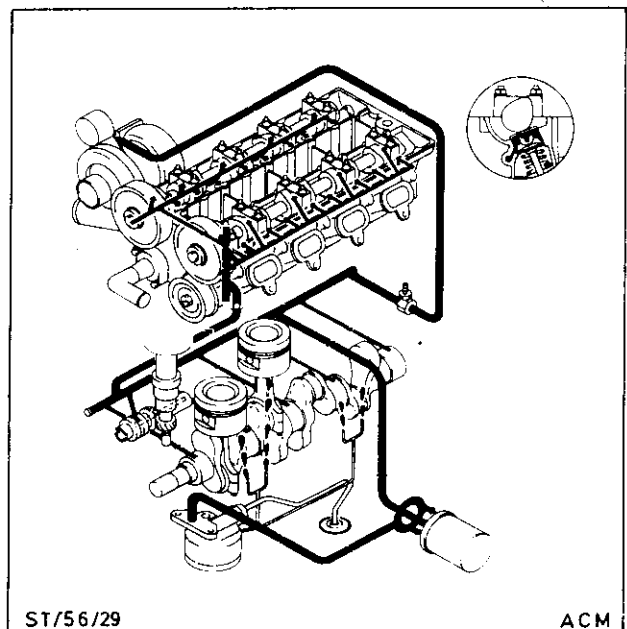

#### Lubrication circuit

## PART A – Engine, Engine Management and Turbocharger

### 1.1 Engine Components

#### The Oilpan

- The Ford Cosworth engine has an aluminium oilpan with internal baffle plate.
- The gasket set for the oilpan is new. The gasket features two cork layers with an aluminium gasket sandwiched between them and 2 additional rubber gaskets.

Since the aluminium oil pan gives the engine block additional strength, the cork/aluminium gaskets must be used.

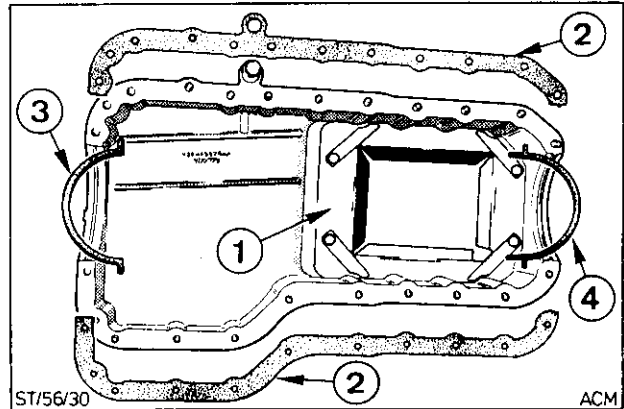

#### Oilpan and gasket

- 1 = Oil baffle
- 2 = Cork/aluminium gasket
- 3 = Front rubber gasket
- 4 = Rear rubber gasket

- The sealing wedges of the rear main bearing are part of the rubber seal and not separated as on the standard OHC engine.

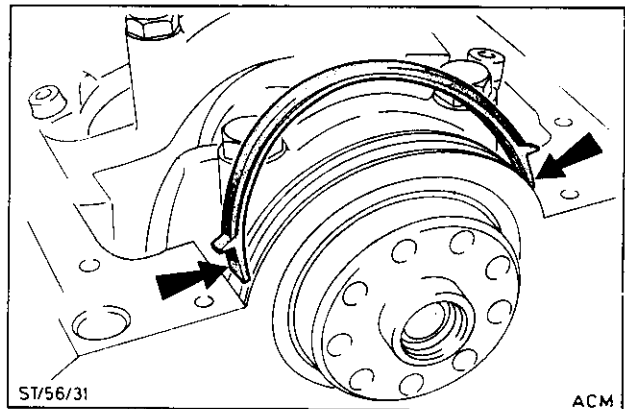

#### Rubber seal – rear main bearing